

INSTRUCTION MANUAL

TRACK SECTION MODULE *MX9V*
plus
Plug-in boards *MX9ALA, MX9AZN, MX9ASE*
and
Display module *MX9ZIA*

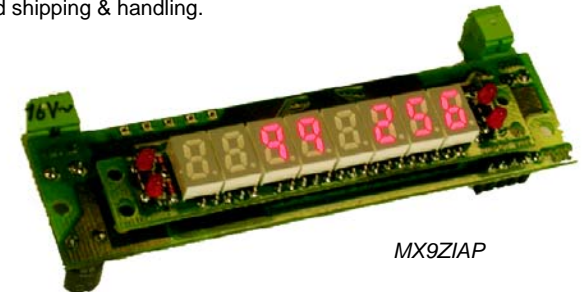
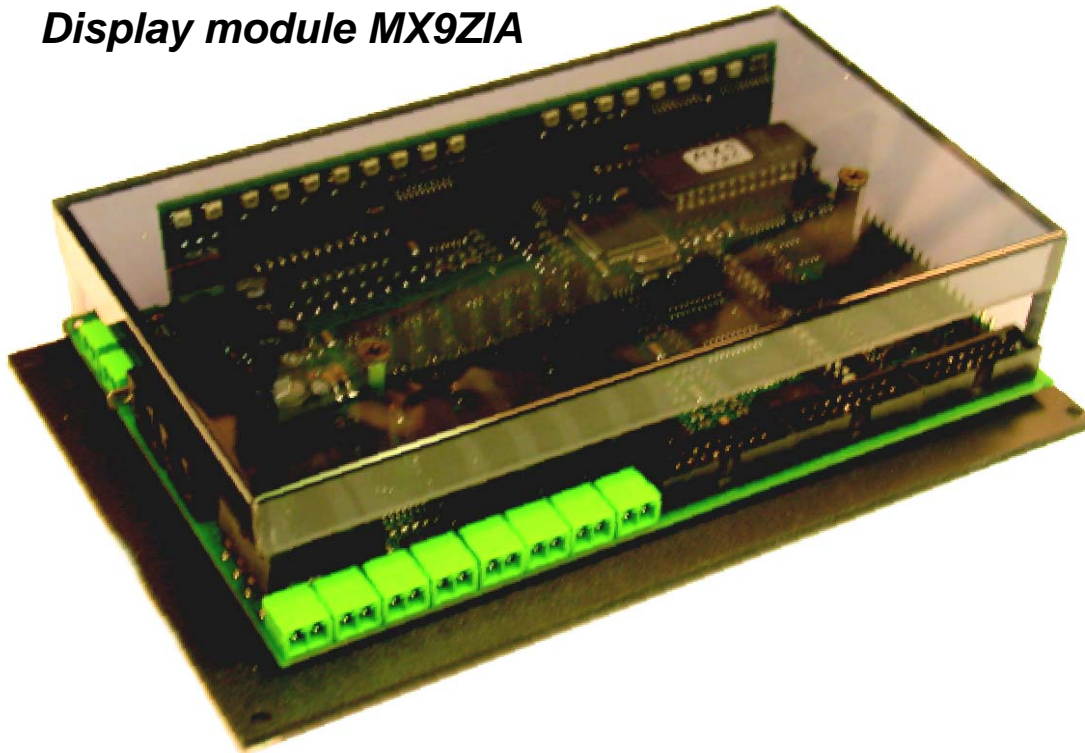

MX9ZIA

EDITION

Old issues (old format) up to 2004 07 15

SW-Version 3.10: several improvements for use with STP software (Operating mode 3) 2006 02 15
 and: module-autonomous applications (Operating mode 1), part one, CV # 21 28 = 141, 142 ... 149 2006 03 02
 2006 04 20
 2007 08 16

ATTENTION: when updating to version 3.03 or higher a HARD RESET must be performed by programming CV #1 = 0!

CHAPTER

0. About this manual	2
1. Introduction	2
2. Technical Information	3
3. Connecting the MX9 to track power and CAN bus	4
4. Addressing and programming the MX9	5
5. Connecting external occupancy indicators and signals	6
6. Connecting external switch inputs	7
7. Loco number recognition and display	7
8. OPERATING MODE 0 (zero)	8
9. OPERATING MODE 1	9
10. OPERATING MODE 2	13
11. OPERATING MODE 3	16
12. Replacing the EPROM	20
13. Increasing the threshold for occupancy detection	20
14. MX9 modifications for MX9ASE applications	21
15. Glossary	21

IMPORTANT NOTES TO SOFTWARE AND SOFTWARE UPDATES:

This product contains an EPROM which stores the software that determines its characteristics and functions.

The current software version may not contain all the functions mentioned in this manual. Such missing functions can be "installed" and possible software glitches corrected later by replacing the EPROM. The ZIMO website at www.zimo.at lists current and new software versions.

New EPROM's can be ordered from ZIMO. The software itself is free but a small fee applies for the new hardware (EPROM) and shipping & handling.

0. About this manual

This instruction manual replaces all previous MX9 manuals. It has been updated and supplemented in many places to include the “**module-autonomous applications**” of the MX9 track section module.

“Module-autonomous” (“operating mode 1”) means that the logical execution of the functions “**stop in front of a red signal**”, “**block control**” and “**hidden station automations**” are performed solely by the MX9, in contrast to a “system-autonomous application”, which is controlled by the command station MX1 (“operating mode 2”) or by a computer (“operating mode 3”).

Attention: All 4 plug-in sockets must be equipped with the additional ASE conductors for most “module-autonomous applications”!!

1. Introduction

Track section modules serve to **monitor sections of track (with one rail isolated)** for

- **Track occupation** and
- **Loco number identification** (optional)

AND for the **application of “location dependent control”** (an international expression summarizing the following functions)

- track-section based “**signal controlled speed influence**”, as described by the **traditional ZIMO** term for speed limit applications F = full speed (no speed limit applied), L = low speed, U = ultra low speed, H = Halt (stop) and the intermediate steps FL, LU, UH,
- track-section based “**location dependent function control**” and the recently introduced
- transmission of track-section based “**position codes**” to decoders.

16 track sections, called subsections, can be connected to a MX9 module. **2 subsections** are always paired together and represent one of eight **main sections**. Speed influence, train number recognition (if board is installed), function control and position-code transmissions are always carried out per main section, that is, for both sub sections simultaneously. Occupancy detection on the other hand is always done independently for each sub section and is a cost-effective and practical arrangement.

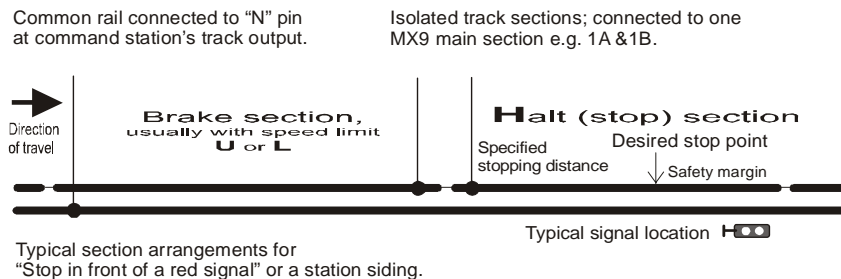

The MX9 is suitable for **several operating modes**, ranging from the **simple “stop in front of a red signal”** in “module-autonomous” application to **computer control**. The MX9 is engineered so that its hardware (the MX9) as well as the arrangements made on the layout (track sections) can be left intact for the various operating modes. The MX9 is integrated in all cases with the CAN bus network and communicates with other system components including a computer, if required:



OPERATING MODE 3: A complete collision avoidance system under computer control (with STP software), mainly for larger layouts.

OPERATING MODE 2: “System-autonomous applications” for more complex block control or routing; i.e. ARS (Automated Route Sequences) using bidirectional communication. The ZIMO command station acts as the brain in the system in place of a computer. Train movements are defined through sample runs or cab inputs.

OPERATING MODE 1: “Module-autonomous applications”. The logical executions of routes through a station or block control of a line is the sole responsibility of the MX9 micro controller, defined by MX9 CV’s. This includes the automatic setting of the appropriate speed limits in both sub-sections in order to bring a train to a stop in front of a red signal.

OPERATING MODE 0 (zero): Direct speed limit assignments to each of the 8 main sections of the MX9; fixed settings through MX9 CV’s or selectable via cab.

Whatever operating mode the MX9 is supposed to operate in, it has to be connected to track voltage and the CAN bus. Equally, signals and occupancy indicators can be connected to the MX9 as well as the loco number identification and display utilized in all operating modes. For this reason, the following chapters of this manual are valid for all operating modes:

2. Technical information
3. Connecting the MX9 to track power and CAN bus
4. Addressing and programming the MX9
5. Connecting external occupancy indicators and signals
6. Connecting external switch inputs
7. Loco number recognition and display

The meaning of individual configuration variables (CV’s) however is in part dependent on the operating mode; therefore they are explained together with the different operating modes in their corresponding chapters:

8. Operating mode 0 (zero)
9. Operating mode 1
10. Operating mode 2
11. Operating mode 3

2. Technical Information

The main board of the MX9, including the sockets for the plug-in boards, are mounted on a sturdy plate and protected with a transparent cover. Status and 16 occupancy indicator LED's are visible through the cover. There are no input elements such as buttons, switches etc. The MX9 is operated strictly via cab or computer.

Optional plug-in boards can be installed at any time as needed:

- A **train number recognition board MX9AZN** reads the train numbers of one of the 8 main sections. The identified numbers are either displayed by external MX9ZIA display modules or sent to a computer.
- 4 sockets are present for the installation of **MX9ALA amplifier plug-in boards** that drive 16 signal bulbs or LED's (e.g. 2-aspect block signals) and 16 external occupancy indicators.
- The "ALA" sockets (all or just some) can alternatively be used for **MX9ASE switch input plug-in boards** that are most often used within the scope of the "module autonomous" application but also for the direct assignment of speed limits (F, L, U, H) of the 8 main sections by means of external switch inputs or relays.

ATTENTION: The MX9 module as delivered does not support MX9ASE boards. Specify if MX9ASE boards are intended to be used when ordering a MX9 so the module will be shipped with the required modifications for the MX9ASE boards to function!

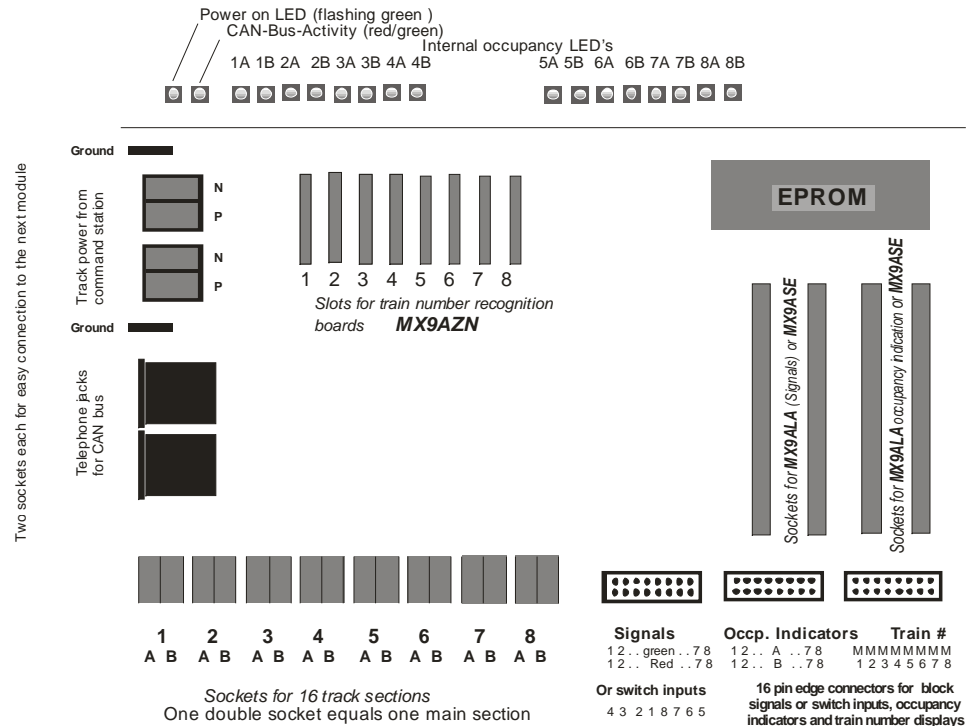

TECHNICAL INFORMATION:

Operating voltage (from output "SCHIENE" at ZIMO command station).....	12 - 24 V
CAN bus voltage.....	12 - 40 V
Max. current at each track output (short circuit cut-off).....	3 - 4 A *)
Allowable maximum current of all outputs.....	8 A
Resistor across axles for reliable occupancy detection.....	12 K - 25 K **)
Idle consumption (CAN bus).....	120 mA
Dimensions.....	6.77"x 4.40" x 1.57" (172mm x 112mm x 40mm)

*) Each block is individually protected against short circuits. The maximum current at which the power to the track section is turned off, depends to a certain degree on the track voltage selected:

At 12 V: power is cut off at @ 2.8 A

At 18 V: power is cut off at @ 3.6 A

At 24 V: power is cut off at @ 4.4 A

***) Resistor values needed for reliable occupancy detection also depends on the selected track voltage:

At 12 V: occupancy is detected with a 13 K Ohm or less resistor across axle

At 16 V: occupancy is detected with an 18 K Ohm or less resistor across axle

At 20 V: occupancy is detected with a 22 K Ohm or less resistor across axle

At 24 V: occupancy is detected with a 35 K Ohm or less resistor across axle

The occupancy detection may be too sensitive for particular applications such as large scale garden railroads (erroneous indications due to moisture!); the sensitivity can be reduced by installing external resistors to the MX9 board, see section 13 "Increasing the threshold for occupancy detection"!

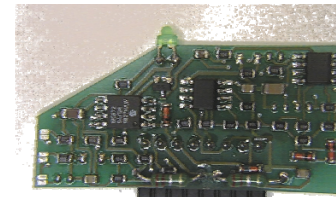

MX9AZN plug-in board.
Important: Bevel must point to rear of MX9, see chapter 7.

Plug-in board
MX9ALA
see chapter 5



Plug-in board
MX9ASE
See chapter 6



3. Connecting the MX9 to track power and CAN bus

This chapter applies to all operating modes (except: computer control only in operating mode 3).

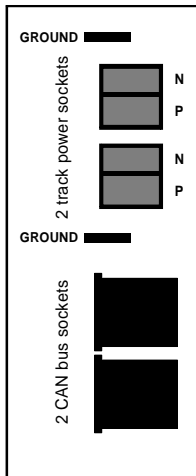

The MX9 has two internally-parallel wired connections each to easily connect it to track power, a common ground and the CAN bus.

The same kind of double-pin sockets are used for the track power hook-up as are found at the command station, spade terminals for the common ground and RJ12 sockets for the CAN bus.

ATTENTION:

This chapter describes how the modules are wired permanently to the layout.

However, BEFORE the modules can be mounted and wired as described here, they each must have their own unique address ranging from 901 to 963.

For this purpose, connect each module separately to the system (command station and cab) and program it with an address of your choice. See the chapter "Addressing and programming the MX9" for this procedure.

Once each module (MX9 track section modules, MX8 accessory modules and possibly other modules) is programmed with its own unique address, it can be connected permanently to the CAN bus and of course to track power and common ground as well.

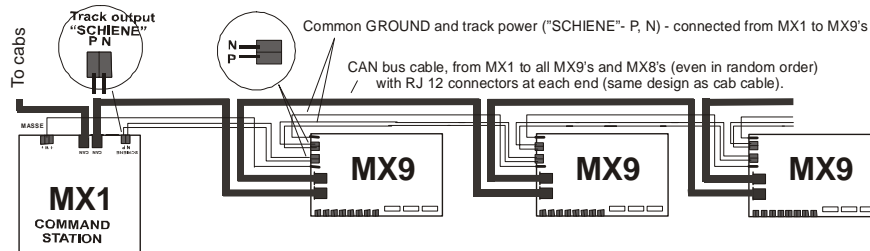

IMPORTANT: The proper pins of the command station's track output have to be used for connecting the MX9; the double socket marked "SCHIENE" (meaning main track) with polarity markings "P", "N". The polarity "P", "N" has to be maintained on all modules! Additionally, an adequate wire size has to be selected for track power and the common ground wire! In most cases that should be a 1.5 mm² (14AWG) wire, smaller N-scale layouts may get away with a 0.75 mm² (22AWG) but large-scale garden layouts need at least 2.5 mm² (10AWG) or 4 mm² wire.

On larger layouts (10 or more modules), the voltage drop across connectors can be of concern and daisy-chaining the CAN bus, track power and common ground between modules should be avoided. It is better to install a bus wire for each and connect small groups of modules to the bus using distribution boxes and the like that are permanently connected with each other (soldered, clamped etc.).

However, the CAN bus should ALWAYS be of the linear type, which means that there should only be relative short wires connecting the single MX9's (or small groups of MX9's) to the CAN bus (pref-

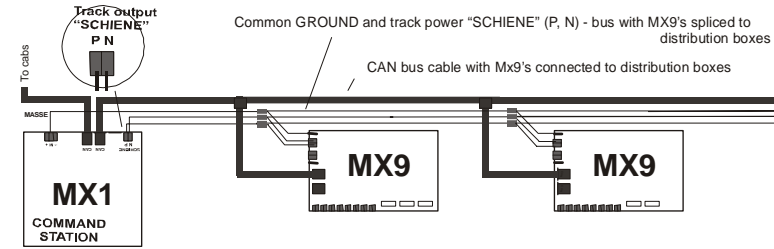

erably <1m (3ft). Track power and common GROUND, on the other hand, can also be laid out in a star formation; the main concern here is that the cables are not unnecessarily long.

Keep track of total CAN bus length! More than 50 m (150ft)?

If the total CAN bus cable length connecting the cabs, track section modules, accessory modules, turn table modules, infrared modules, computer and more exceeds 50 m (150 feet), termination resistors (typically 150 to 330 ohm) should be installed at both ends of the CAN bus (at an empty CAN bus socket of the first and last component) between the pins CAN "H" and CAN "L". Several hundred meters of CAN bus length are possible with resistors installed. Instead of making your own resistor-equipped plugs, finished connectors can also be ordered from ZIMO with part number 6POLWID.

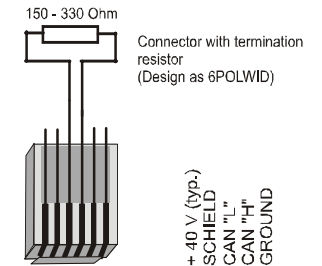

CAUTION, when wiring 110V in close proximity to the layout! 110V wires that run parallel for larger distances of more than one meter (>3ft) or are bundled together with track wires or CAN bus wires can cause interference!

COMPUTER connection to the CAN bus

("Operating mode 3" – Computer control with STP):

The computer is connected with its serial interface (9-pin) or via USB and the STP CANKey. The CANKey is connected with a common CAN bus cable to the command station (or any other free CAN bus socket on the layout). If more connecting capabilities are required than the two sockets of the MX1 command station, a distributor box like the 6POLTRIP can be used.

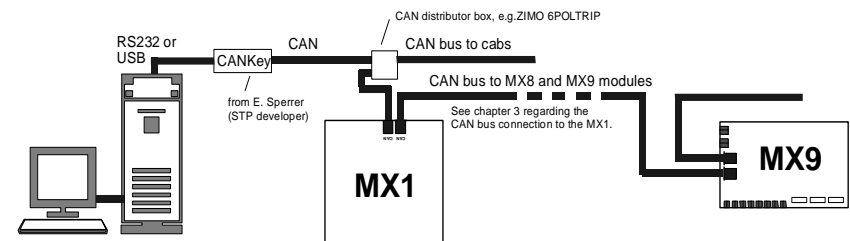

4. Addressing and programming the MX9

Assigning an address to (and often programming) a MX9 is **necessary for ALL operating modes**. Only after the address has been changed from the default address 900 can the module be distinguished from other MX9 modules on the bus and used in operation!

CONNECTING the CAN BUS CABLE - POWERING THE MX9

The processor is powered through the CAN bus, which is made visible through the row of LED's at the back of the MX9: first by displaying the EPROM version code and immediately after that by **flashing all 16 occupancy indicator LED's in sequence from left to right (chase lights)**.

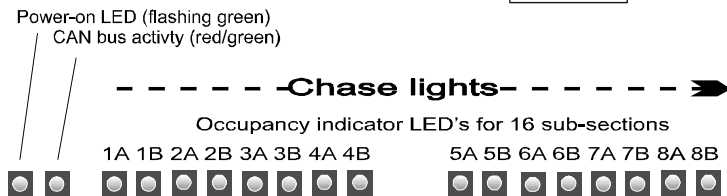
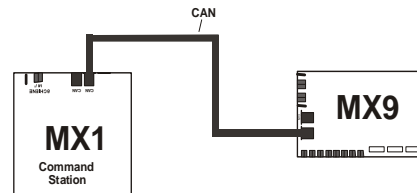

The chase lights are also useful as an LED check. If a single LED does not light up briefly, it is most likely defective. If none of them light up or uncontrolled flickering is observed, the module itself is defective.

After that, the power-on control LED (far left) starts blinking green thereby indicating that the MX9 is operational. The LED to the right starts flashing red/green indicating that there is activity on the CAN bus.

ERROR DISPLAY:

- All 16 occupancy indicator LED's flash in unison once per second:
Module is programmed to default address 900.
- LED's 5A to 8B, which is the complete right LED group flashes as above
(at the same time the left LED group indicates a coded binary address):
Address conflict (same address is used on more than one MX9) !
No operation is possible unless this is corrected.
- Power-on LED, CAN bus LED and every second occupancy LED flashes:
EPROM is defective!
- CAN bus LED flashes, power-on LED remains dark:
Module needs to be repaired, defective EEPROM!
- CAN bus LED flashes rapidly, power-on LED flashes normal:
track power without valid DCC signal present!

ASSIGNING AN ADDRESS TO A MX9 MODULE:

Each MX9 requires its own address, which is used to access the track sections connected to it. Each address must be unique, meaning the same address cannot be used for another MX9. Each MX9 is programmed with the default address 900 at time of delivery. Allowable addresses that can be used for actual layout operations range from 901 to 963.

Programming an MX9 with one of these addresses (901 to 963) is only possible:

- if it is **programmed first to the default address 900** (recognizable by the 16 LED's flashing in unison) AND
- the MX9 about to be programmed is the only track section module connected to the CAN bus containing the address 900! Any number of other modules though (cab's and accessory modules as well as all other MX9's that already contain an address other than 900) may be connected to the CAN bus during this procedure.

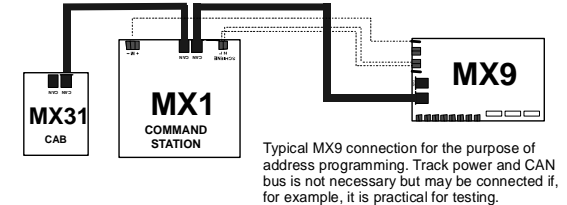

Please check the appropriate **cab instruction manual (MX21, MX31 etc.)** regarding the addressing procedure.

DELETE AN EXISTING MX9 MODULE ADDRESS (RESETTING TO ADDRESS 900):

This is only possible if the MX9 in question is the only one connected to the CAN bus!

After the MX9 is programmed to address 900, it can be reprogrammed again to any of the available addresses (901 to 963), see above.

Note: Deleting an address by **Programming to the default address 900 does not initiate a hard reset** (resetting of all CV's).

However: Programming **CV #1 to 0** does initiate a **hard reset** and with it also changes the address to 900.

READING OUT THE CURRENT ADDRESS:

Reading out an MX9 address is only possible if this is the only MX9 connected to the CAN bus.

Please check the appropriate **cab instruction manual (MX21, MX31 etc.)** regarding the read-out procedure.

PROGRAMMING AND READING OF MX9 CONFIGURATION VARIABLES:

CV programming, in contrast to address programming, is also possible with many MX9's connected to the CAN bus, provided the MX9 address is known to the user. The MX9 address must be entered first during this procedure so that only the CV's of the intended MX9 are being reprogrammed. **Please check** the appropriate **cab instruction manual (MX21, MX31 etc.)** regarding the read-out procedure.

THE CONFIGURATION VARIABLES . . .

Because the meaning of the configuration variables partly depends on the operating modes (0 ...4), they are explained in the corresponding chapters 8....11.

5. Connecting external occupancy indicators and signals

This chapter is valid for MX9 applications in ALL operating modes; however exceptions and special circumstances do apply for some.

16-pin edge connectors are available for the connection of light bulbs or LED's for occupancy indicators or signals (all commercially available types with a common anode); for a total of 32 "Light" outputs per MX9.

The outputs are however only active if the associated MX9ALA amplifier boards are plugged in (two each for signals and occupancy indicators).

All light outputs are so-called open collector outputs, which mean that a load (light bulb or LED with resistor) connected to the MX9 output is pulled low, towards the ground side; the other side of the load needs to be connected to DC power (max. 24V).

DC voltage can be used from an external DC power supply (max. 24V), from the DC output of a model railroad transformer (check for proper polarity!) or the positive voltage supplied by the command station (on all MX1: "+" pin of 3-pin socket next to the transformer input(s)).

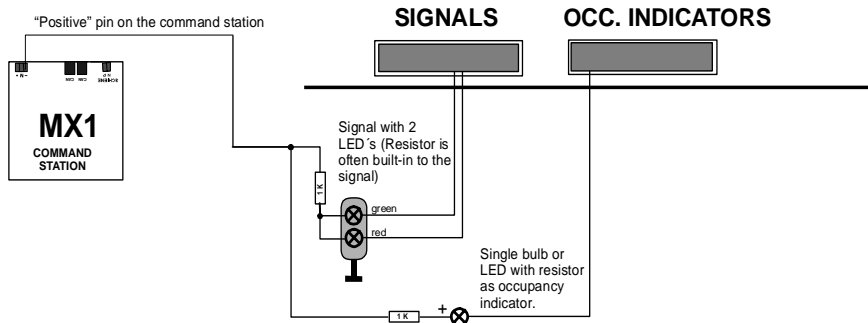

Or:

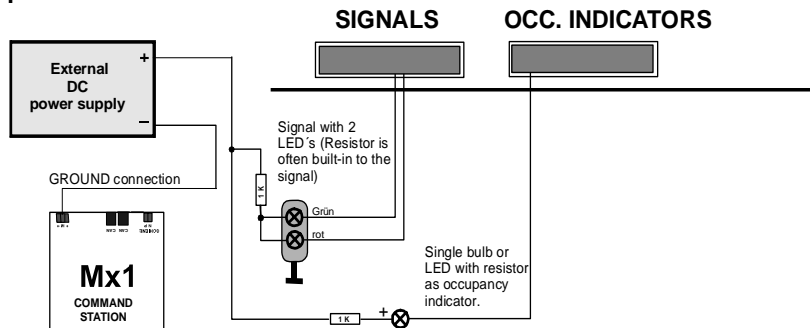

LIGHT OUTPUT ASSIGNMENTS, if not defined differently . . . :

The occupancy indicator output pins are directly connected with the 16 track sections (sub-sections). See drawing below. The signal outputs are intended for block signals of the 8 main sections and will show "stop" (red) if a train is supposed to stop at the end of an associated block.

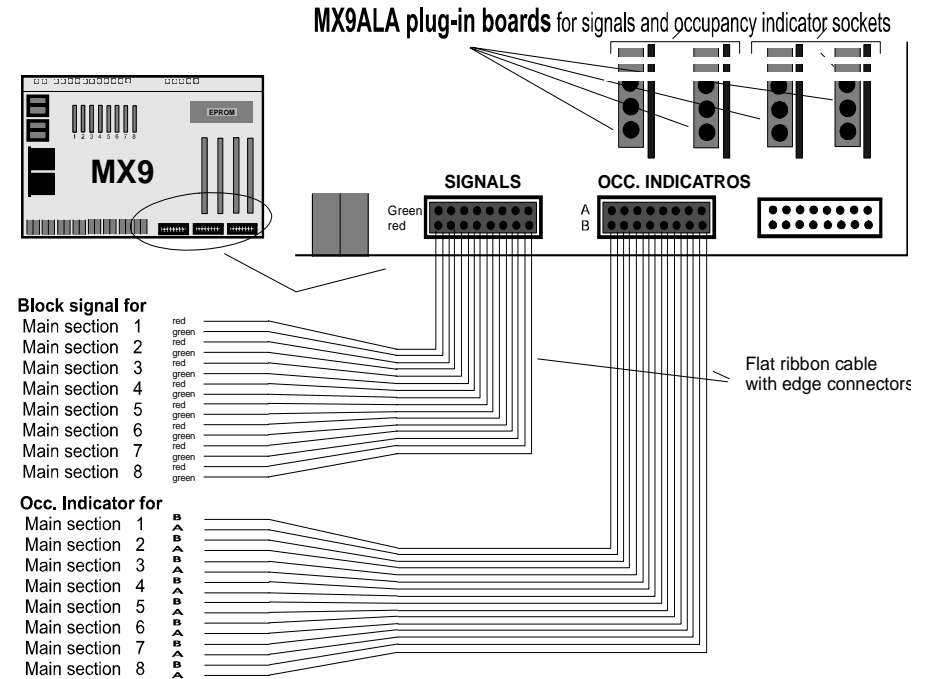

NOTES to special assignments of bulb outputs in . . . :

OPERATING MODE 1 („module-autonomous applications“, see chapter 9):

In relationship to the contents of CV #21 ... 28 (one CV for each main section), the sockets "OCC. INDICATOR" can be used with the MX9ALA plug-in boards to control signals in the opposite driving direction; or MX9ASE boards can be plugged in to accept external switch inputs.

OPERATING MODE 2 („system-autonomous applications“, see chapter 10):

Generally speaking, the outputs are used as shown in the above schematic, but if the command station is used for processing logic functions it can make its own assignments.

OPERATING MODE 3 (Computer-control applications, see chapter 11):

All 32 outputs are defined by the software of a computer application; it is up to the computer software (e.g. STP switch board) to decide whether the outputs are used as occupancy indicators or signals. For example, all 32 outputs could be used for signals – including multi-aspect – since hardware solutions for occupancy indications will hardly be required.

6. Connecting external switch inputs

Used primarily with **OPERATING MODE 0** and **1**.

External switches or push button switches can be connected to these inputs for switching between speed limits (H, L, U, F) of selected track sections or controlling a signal influenced block (Proceed or stop). Since the same plug-in board sockets and edge connectors are used as for the bulb outputs, certain applications are mutually exclusive.

ATTENTION:

the **MX9 module** must be **modified** before **MX9ASE** plug-in boards can be installed and switches used as input signals. **MX9ALA** boards on the other hand can be installed at any time

This modification is performed by **ZIMO** on request (additional internal conductors from the processor to the plug-in sockets, which are not present on the printed circuit board), even after the modules have been delivered.

We're considering having this modification carried out on all **MX9** modules during production, starting later in 2006.

The second terminal of the switches is to be connected with system **GROUND**.

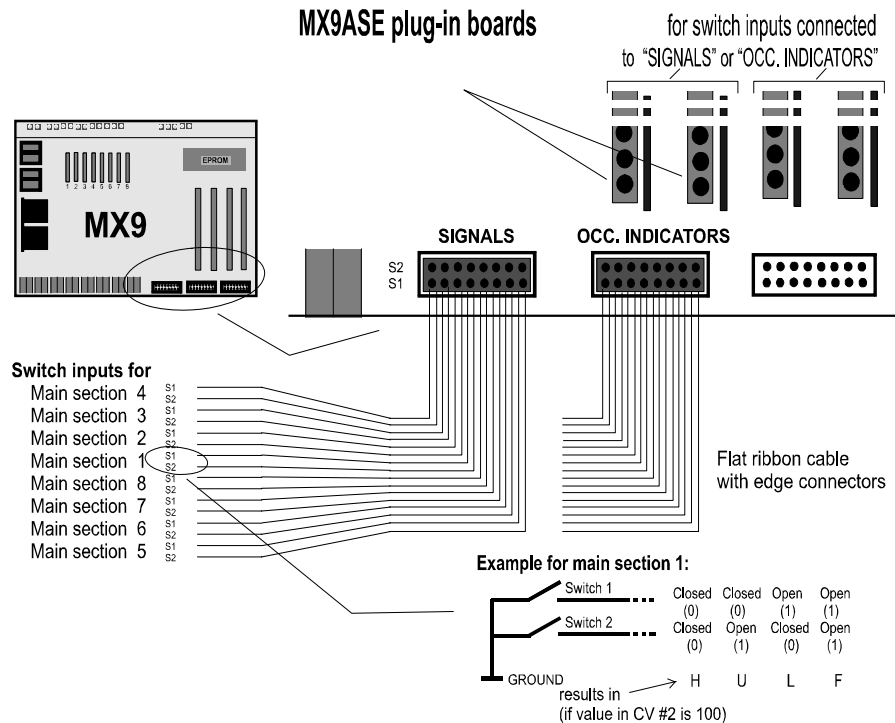

OPERATING MODE 0 (fixed speed limits, see chapter 8) uses the connector "SIGNALS" and the two associated plug-in board sockets on the left, while with **OPERATING MODE 1** (module-autonomous applications", see chapter 9) the connector "OCC. INDICATORS" and the plug-in board sockets on the right are most often used.

7. Loco number recognition and display

Applicable for **ALL** operating modes!

IMPORTANT: Position the **MX9AZN** so that the bevel points to the rear of the **MX9**!

MX9AZN Plug-in boards for the 8 main sections

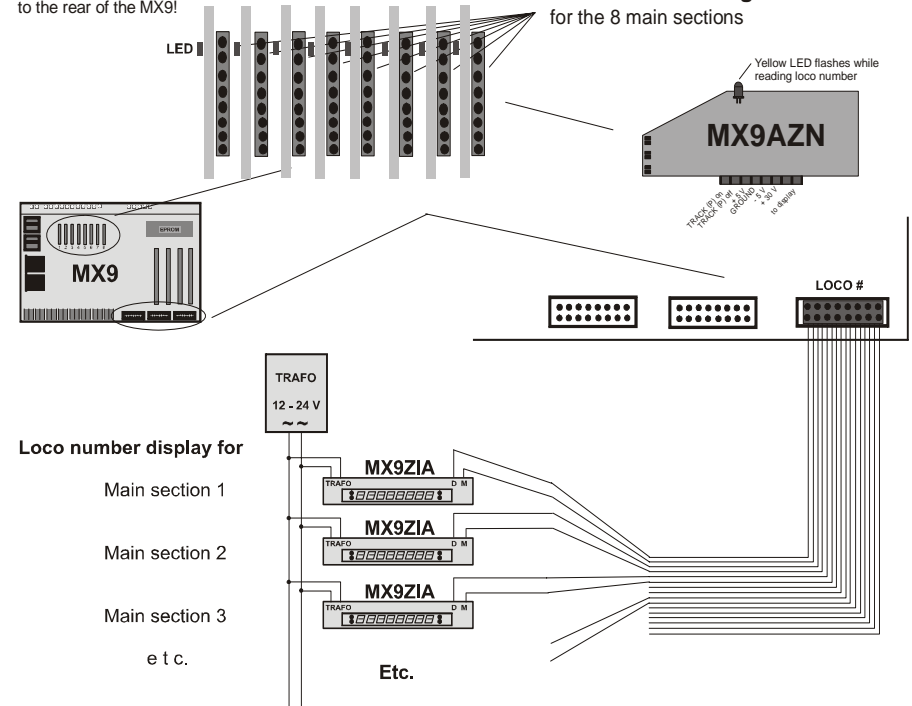

The main-section based loco number recognition is carried out by the **MX9AZN** boards; up to 4 addresses can be recognized simultaneously. The information is sent via the CAN bus upon request. Most often the loco numbers are being displayed on a computer switch board and will be used by the computer for other purposes (Routing with STP etc.).

With the help of the **MX9ZIA** display modules (see wiring diagram above), the loco numbers can also be displayed "live". The **MX9ZIA** contains 8 seven-segment LED's in red and is capable of displaying 1, 2 or 3 addresses simultaneously or alternating between them.

8. OPERATING MODE 0 (zero)

Operating mode 0 means that main sections are set to a speed limit which remains unchanged; no influence from the system (computer) or device-autonomous.

CV	Name	Range	Default	Description
#1	Module Address (stored without the leading "9") Identical for ALL operating modes	0 – 63 = 900 – 963 Programming a new address is only possible if module address is 900! Programming to address 900 = deleting current address	0 = 900	The address that is used to access the module with the cab or computer (STP...) Externally (i.e. at the cab), the address is displayed as 900 ... 963 , internally as a CV however, it is stored as 0 ... 63. CV # 1 = 0, causes a HARD RESET - all CV's are reset to the default values including the address, which is set to 900. Normal reprogramming of the address to 900 DOES NOT cause a hard reset. It'll only change CV #1 to 0; all other CV's remain untouched.
#2 #3 #4 #5 #6 #7 #8 #9	Speed limits that are applied to the main sections after power-up Main section 1 Main section 2 Main section 3 Main section 4 Main section 5 Main section 6 Main section 7 Main section 8	0 - 7 / 0 - 7	0 (Default 0 corresponds to "33", which means no speed limit in either direction)	The CV's 2 ... 9 supplement the definition of the associated main section in the CV's #21 to 28. Tens digit: speed limit in opposite direction of signal protected block. Ones digit: speed limit in defined direction of signal protected block when signal is "green" (F). ZIMO speed limit codes: Value 0= „H“ (Halt or stop) Value 1= „U“ (Ultra low speed) Value 2= „L“ (Low speed) Value 3=: „F“ (Full speed) Value 5, 6, 7=: Intermediate steps „1/6“, „3/6“, „5/6“ Bit 4 = 1: the first direction bit in HLU info Bit 5 = 1: the second direction bit in HLU info HLU direction bits: see decoder manuals since 2005
#10 #11 #12 #13 #14 #15 #16 #17	Function bits Main section 1 Main section 2 Main section 3 Main section 4 Main section 5 Main section 6 Main section 7 Main section 8	0 - 255	0	Each bit of the CV concerned corresponds to one of 8 function bits that can be actuated with the "location dependent function control" feature. One CV for each of the 8 main sections of the MX9. Identical for ALL operating modes
#18	"Signal controlled speed influence" timing: Start of the "HLU" bits	0 - 255	SW <3.03=64 SW > 3.03=130	Problems usually caused by wiring issues, which are affecting the operation of the MX9 can be compensated for with the help of these CV's. There is no need to change these settings under normal conditions!

CV	Name	Range	Default	Description
#19	Duration of the "HLU" bits		136	Identical for ALL operating modes
#20	Special configurations	0, 4, 8, 12	0	Bit 2 = 0: Signal outputs initialized when power-on. = 1: ... not initialized Bit 3 = 0: Normal operation of the track outputs = 1: High current operation; 2 outputs form parallel outputs each: 1A + 5A, 1B + 5B, 2A + 6A, 2B + 6B, etc.
#29	Supplementary definitions for the "module-autonomous" operating mode			Bit 0 = 0 Sockets OCC. INDICATOR are used for occupancy indication (plug in MX9ALA boards) = 1 Sockets OCC. INDICATOR are used according to Bit 1 Bit 1 = 0 Sockets OCC. INDICATOR are used for signals in opposite direction (plug in MX9ALA) = 1 Sockets OCC. INDICATOR are used for switch-inputs, for both directions where applicable (plug in MX9ASE)

9. OPERATING MODE 1

MODULE-AUTONOMOUS APPLICATIONS

The following table of configuration variables and the subsequent table of “Values for CV # 21 to 28” serve as a reference for the OPERATING MODE 1. Because the meanings and relationships of the information cannot be fully explained with these tables alone, we added some **application examples** at the end of this chapter!

CV	Name	Range	Default	Description
#1	Module Address (stored without the leading “9”) Identical for ALL operating modes	0 – 63 = 900 – 963 Programming a new address is only possible if module address is 900! Programming to address 900 = deleting current address	0 = 900	The address that is used to access the module with the cab or computer (STP...). Externally (i.e. at the cab), the address is displayed as 900 ... 963 , internally as a CV however, it is stored as 0 ... 63. CV # 1 = 0, causes a HARD RESET - all CV’s are reset to the default values including the address, which is set to 900. Normal reprogramming of the address to 900 DOES NOT cause a hard reset. It’ll only change CV #1 to 0; all other CV’s remain untouched.
#2 #3 #4 #5 #6 #7 #8 #9	Initial speed limits that are applied to the main sections after power-up Main section 1 Main section 2 Main section 3 Main section 4 Main section 5 Main section 6 Main section 7 Main section 8	0 - 7 / 0 - 7	0 (Default 0 corresponds to “33”, which means no speed limit in either direction	The CV’s 2 ... 9 supplement the definition of the associated main section in the CV’s #21 to 28. Tens digit: speed limit in opposite direction of signal protected block. Ones digit: speed limit in defined direction of signal protected block when signal is “green” (F). ZIMO speed limit codes: Value 0= „H“ (Halt or stop) Value 1= „U“ (Ultra low speed) Value 2= „L“ (Low speed) Value 3= „F“ (Full speed) Value 5, 6, 7=: Intermediate steps „1/6“, „3/6“, „5/6“ Bit 4 = 1: the first direction bit in HLU infot Bit 5 = 1: the second direction bit in HLU info HLU direction bits: see decoder manuals since 2005
#10 #11 #12 #13 #14 #15 #16	Function bits Main section 1 Main section 2 Main section 3 Main section 4 Main section 5 Main section 6 Main section 7	0 - 255	0	Each bit of the CV concerned corresponds to one of 8 function bits that can be actuated with the “location dependent function control” feature. One CV for each of the 8 main sections of the MX9. Identical for ALL

CV	Name	Range	Default	Description
#17	Main section 8			operating modes
#18	“Signal controlled speed influence” timing: Start of the “HLU” bits	0 - 255	SW <3.03=64 SW > 3.03=130	Problems usually caused by wiring issues, which are affecting the operation of the MX9 can be compensated for with the help of these CV’s. There is no need to change these settings under normal conditions! Identical for ALL operating modes
#19	Duration of the “HLU” bits		136	
# 20	Special configurations	0, 4, 8, 12	0	Bit 2 = 0: Signal outputs initialized when power-on. = 1: ... not initialized Bit 3 = 0: Normal operation of the track outputs = 1: High current operation; 2 outputs form parallel outputs each: 1A + 5A, 1B + 5B, 2A + 6A, 2B + 6B, etc.
#21 #22 #23 #24 #25 #26 #27 #28	Signal influenced block definition Main section 1 Main section 2 Main section 3 Main section 4 Main section 5 Main section 6 Main section 7 Main section 8	Choose the values from the value table below	0	Defines the functionality of each signal influenced block. See the table “Values for CV’s 21 ...28, below! However: A value of “0” defines operating mode 2 or operating mode 3 For the respective main section (see chapter 10, 11)!
#29	Supplementary definitions for the “module-autonomous” operating mode			Bit 0 = 0 Sockets OCC. INDICATOR are used for occupancy indication (plug in MX9ALA boards) = 1 Sockets OCC. INDICATOR are used according to Bit 1 Bit 1 = 0 Sockets OCC. INDICATOR are used for signals in opposite direction (plug in MX9ALA) = 1 Sockets OCC. INDICATOR are used for switch-inputs, for both directions where applicable (plug in MX9ASE)

Track section, Block, Route, Switch ladder, Track, Main section . . .

The linguistic use of these expressions is neither entirely consistent in the field of model railroading nor inside the ZIMO documentations; see “Glossary” at the end of this manual !

Values for CV's #21 ... 28 in OPERATING MODE 1 ("module-autonomous applications")

0						
10		U-H		A -> B		
110		U-H			B -> A	
210		U-H		A -> B	B -> A	
20			L-H	A -> B		
120			L-H		B -> A	
220			L-H	A -> B	B -> A	
30		U-H		A -> B	dep. on occupation of next main section (n+1 or 1 if n=8)	
130		U-H			dep. on occupation of previous main section (n-1 or 8 if n=1)	
40			L-H	A -> B	dep. on occupation of next main section (n+1 or 1 if n=8)	
140			L-H		dep. on occupation of previous main section (n-1 or 8 if n=1)	
31, 32, .. 38	U-H			A -> B	dep. that section defined in ones digit is free	
131,132,..138	U-H				B -> A	dep. that section defined in ones digit is free
41, 42, .. 48		L-H		A -> B	dep. that section defined in ones digit is free	
141,142,..148		L-H			B -> A	dep. that section defined in ones digit is free
39		U-H		A -> B	dep. on occ. of next MX9, main section 1	
139		U-H			B -> A	dep. on occ. of previous MX9, main section 8
49			L-H	A -> B	dep. on occ. of next MX9, main section 1	
149			L-H		B -> A	dep. on occ. of previous MX9, main section 8
50		U-H		A -> B	Staging yard	
150		U-H			B -> A	Staging yard
60			L-H	A -> B	Staging yard	
160			L-H		B -> A	Staging yard
51, 52, .. 58	U-H			A -> B	Staging yard with switch command	
151,152,..158	U-H				B -> A	Staging yard with switch command
61, 62, .. 68		L-H		A -> B	Staging yard with switch command	
161,162,..168		L-H			B -> A	Staging yard with switch command

The bracket at the right table border indicates the first part of the "module-autonomous applications" as implemented with software version 3.10. More details to follow later.

The properties of each main section in operating mode 1 is determined by a corresponding CV. For example, CV #21 for main section 1, CV #22 for main section 2 etc.
 The two sub sections of a main section form a "signal influenced block". A signal on one end, in many cases on both ends, protects the block. At the end of such a block trains should stop on demand if the signal influenced block is switched to "stop" and the signal shows "red".
 "Signal influenced blocks" are used in block control or in stations, which are set to "Stop" or "Go" either manually or automatic.
 The different values in the table at the left (i.e. CV #21, 22, 23 etc = „10“, „110“, „210“, „20“etc) define the brake characteristic and affected travel direction of a "signal influenced block" and in part the inter-dependency of other signal influenced blocks when occupied or free.

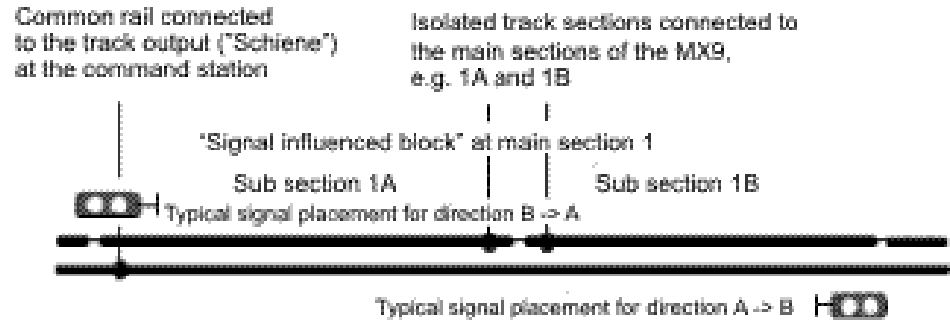

The meanings of the abbreviations in the table are:
 A -> B direction: Train enters first sub section A and, if the signal is "red", stops at the end of sub section B.
 B -> A direction: Train enters first sub section B and, if the signal is "red", stops at the end of sub section A.
 U - H: The train slows down to speed limit "U" (Ultra low speed) in the first section, if the signal is "red", and stops in the second sub section ("H").
 L - H: The train slows down to speed limit "L" (Low speed) in the first section, if the signal is "red", and stops in the second sub section ("H").
 For automated block control and hidden stations (Value 30 or higher) additional information is included that defines under which conditions the signal influenced block is set to "Stop" or "Go". For example: "n+1" means "the following block in direction A->B", "n+8" means "the following block in direction B->A".

Example for CV #21 = 10 (first line in the table to the left):
 Main section 1 will be used for a "uni-directional signal influenced block" in direction A -> B and with brake characteristics U - H, which means that trains entering the sub section 1A will be slowed down to speed limit "U" and stopped ("H") in sub section 1B. The state of the signal influenced block can be changed to stop ("H") or go ("F") with the cab or an external switch.
 The following pages show **APPLICATION EXAMPLES** that explains the individual cases in detail.

**APPLICATION EXAMPLE –
Manually operated unidirectional signal influenced block (“Stop in front of a red signal”)**

This represents the simplest case within the scope of the “module-autonomous applications”: the two sections of one MX9 main section are assigned to one signal; up to 8 such signal influenced blocks can be operated independently of each other through a MX9.

The signal influenced blocks are switched between “Stop” and “Go” (including signals, if connected) using the digit key on the cab that corresponds to the block number, after activating the MX9 module address. The same can also be accomplished with external switches provided MX9ASE boards are plugged in (see chapter “6. Connecting external switch inputs”).

Referring to the drawing below, with a signal influenced block set to “Halt” (red signal), a train entering section A from the left should slow down to speed limit “L” and come to a full stop in section B.

Note: A pusher train (with the engine at the rear of the train) won’t start to slow down until the engine enters section A, but if the decoder’s “distance controlled stopping” feature is active it will nonetheless come to a full stop in front of the signal.

The track sections return to their initial state (which is “F” or the speed limit defined for the opposite direction, see “Initial speed limits” in the CV table above) when the whole signal influenced block becomes unoccupied (both track sections), regardless whether the train left because the signal turned “green” or by overriding the signal using the “MAN” key on the cab. The signal influenced block is now ready for the next train.

Applicable CV settings for this example (Signal influenced block at main section 3 of the MX9):

CV # 23 = 20 (assuming that the speed is to be reduced to “L” (low speed);
reducing the speed to “U” (Ultra low speed) requires CV #23 = 10)

CV # 4 = optional: if a speed limit should apply in the opposite direction and/or in the anticipated direction with a “green” signal; see “Initial speed limits” in the CV table above.

CV # 29, Bits 1.0 = 00 if OCC. INDICATORS socket is empty or used for occupancy detection
= 11 if socket is used for external switch inputs (ASE plugged in, drawing below)

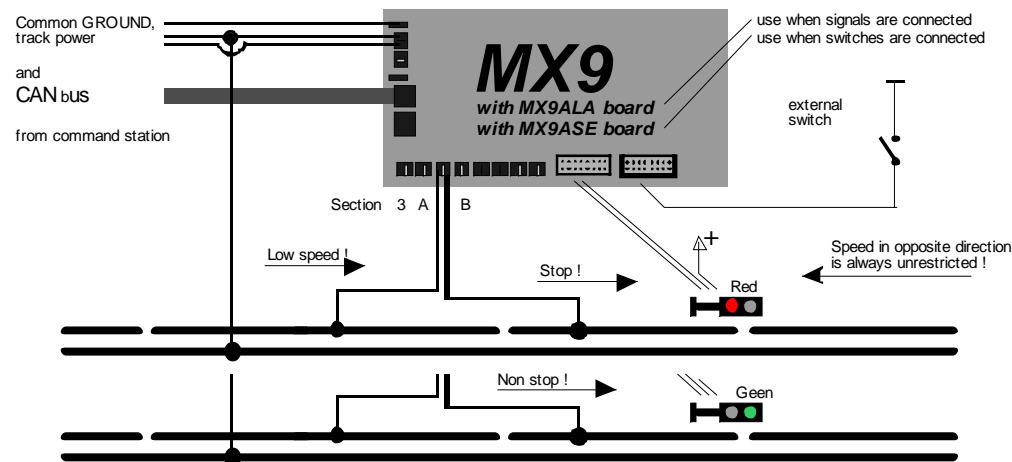

**APPLICATION EXAMPLE –
Manually operated bidirectional signal influenced block (“Stop in front of a red signal”)**

Operation is similar as in the previous example except that trains can enter from either direction and stop at the end of the block, which is in the second section at the respective signal.

Bidirectional signal influenced blocks can also be controlled with the cab or external switches; “stop” or “go” in both directions but also “stop” in one direction only and unrestricted passing in the other.

Limits: Because of a limited number of available sockets for plug-in boards either signals or switches can be used, but not both at the same time!

Applicable CV settings for this example (Signal influenced block at main section 2 of the MX9):

CV # 22 = 210 (assuming that the speed is to be reduced to “U” = Ultra low speed).

CV # 3 = optional: for limited speed if the signal is “green”;
see “Initial speed limits” in the CV table above.

CV # 29, Bits 1.0 = 00 if OCC. INDICATORS socket is empty or used for occupancy detection
= 01 if socket is used for signals in opposite direction (drawing below)
= 11 if socket is used for external switch inputs (ASE plugged in, next drawing)

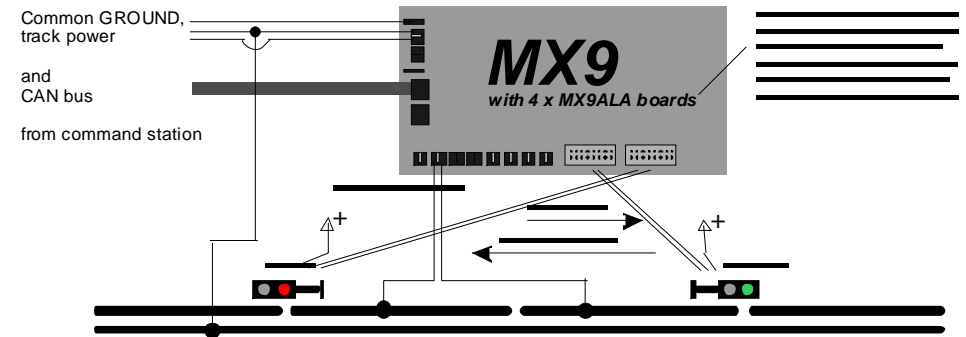

Top drawing: Plug-in sockets are used for MX9ALA to connect signals only.

Bottom drawing: Plug-in sockets are used for MX9ASE to connect external switches; Signals can therefore only be connected to the MX9 for one direction, signals for the opposite direction can be controlled with relays for example (drawing) or double-pole switches.

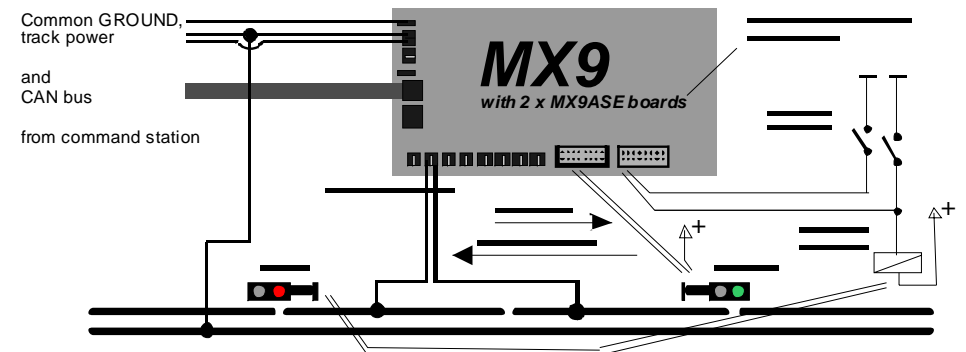

APPLICATION EXAMPLE –

Module-autonomous block control

In contrast to the previous examples, here the main sections of the MX9 are linked to each other. The status of a signal influenced block (whether it is set to “stop” or “go”) depends on the occupancy state of the following block.

The mode of action when trains are stopped inside a block is identical to the previous examples (including when pusher trains are involved).

Automatic block control, which is the usual operating mode and is indicated by yellow keyboard LED’s on the cab, can be overridden to issue a “Stop” (red LED) or “Go” (green LED) command to any block by pressing the relevant key on the cab or by switches connected to the MX9 (with MX9ASE boards plugged-in).

Block control can be laid out cyclically, that is the last block depends on the state of the first block (see example below), but may also end in a manually controlled signal influenced block or in an entry block to a staging yard.

Applicable CV settings for this example (Signal influenced block at main section 3 of the MX9):

- CV # 21 = 40 (Stopping with L-H, because block 1 is longer in this example)
- CV # 22 = 30 (Stopping with U-H, because the stop section here is shorter)
- CV # 23 = 31 (The ones digit in the value “31” defines a cyclical dependency of block 1)
- CV # 2, 3, 4 = optional: for limited speed when “green” and in opposite travel direction; see “Initial speed limits” in the CV table above.
- CV # 29, Bits 1.0 = 00 if “OCC. INDICATORS” socket is empty or used for occupancy detection
- = 01 if socket is used for signals in opposite direction
- = 11 if socket is used for external switch inputs (ASE plugged in)

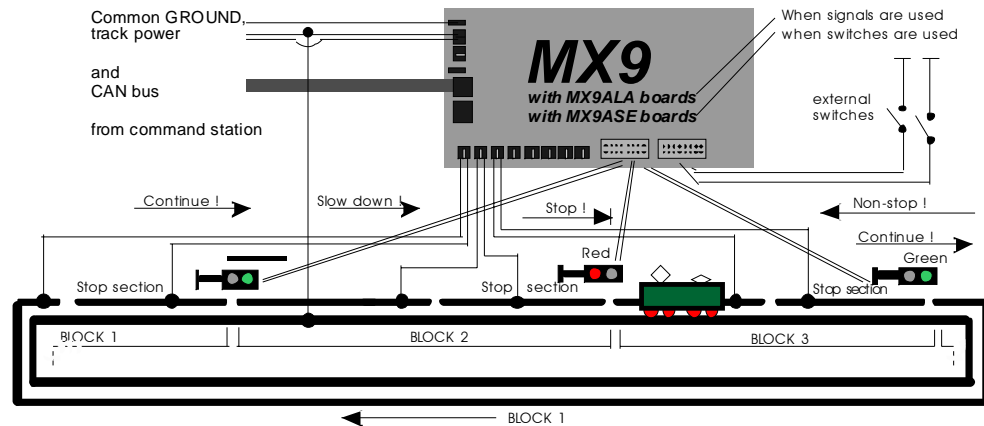

The same example but with bidirectional block control using the same sections:

If block control for the track sections in this example should also be possible in the opposite direction, then the CV’s need to be programmed for this mode.

- CV # 21 = 143 (The ones digit in the value „143“defines a cyclical dependency of block 3)
- CV # 22 = 130
- CV # 23 = 130
- CV , 29, Bits 1, 0 = 01 as mentioned above, for signals in opposite direction

Track section module MX9

APPLICATION EXAMPLE –

Module autonomous staging yard

This block in detail looks as follows:

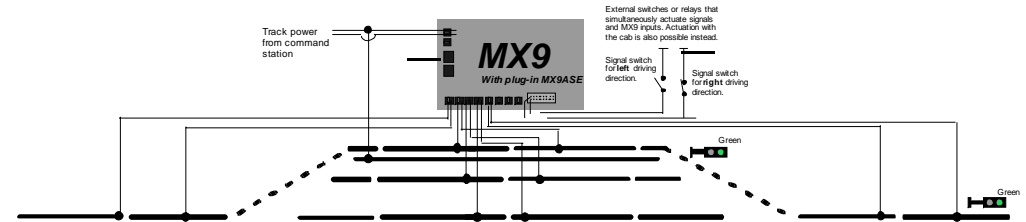

- CV # 21 = 30 Station entry block with signal
- CV # 22 = 51 (first track in staging yard, pin #1 for turnout actuation)
- CV # 23 = 53 (second track in staging yard, pin #2 for turnout actuation)
- CV # 24 = 54 (third track in staging yard, pin #3 for turnout actuation)
- CV # 25 = 30 Block following the staging yard

CV # 3, # 4, # 5 = 23 (this as an additional definition to CV #21, #22 and #23, not as main definition as is normally the case):

That is, trains in direction A->B are to drive through with speed limit L (=2) if signal is green but trains traveling from B->A are to drive without speed limit (=3).

Signals for A->B can be connected to socket SIGNALS (if MX9ALA are plugged in);

Switches for actuating a route can be connected to the socket SIGNALS if MX9ASE is installed; this excludes signals from being plugged in at the same time.

The individual track sections can also be controlled by the cab; LED above key is yellow if in normal mode (=automatic), switching LED to red or green overrides automation and forces the signal to its corresponding state.

OTHER PARAMETERS FOR THE OPERATION OF HIDDEN STATIONS?

CV’s for hidden stations (fiddle yards)
HAS NOT BEEN FINALIZED YET!

10. OPERATING MODE 2

SYSTEM-AUTONOMOUS APPLICATIONS

In the operating mode 2 the command station is in charge of operations, similar in function to a computer as in operating mode 3. "System-autonomous" (operating mode 2), in contrast to "module-autonomous" (operating mode 1), can execute more difficult tasks that involve the cooperation of a larger number of system components that, besides MX9 track section modules, may also include MX8 accessory modules, accessory decoders and more.

The description of the 'system-autonomous' applications should really be in the command station and cab manuals but for "historical" reasons, though, we decided to place the "**system-autonomous block control**" right here in this manual.

The configuration variables in the following table generally cover all system-autonomous applications (operating mode 2), and there is no difference (at least no essential difference) to the CV's used under computer control (operating mode 3).

CV	Name	Range	Default	Description
# 1	Module Address (stored without the leading "9") Identical for ALL operating modes	0 – 63 = 900 – 963 Programming a new address is only possible if module address is 900! Programming to address 900 = deleting current address	0 = 900	The address that is used to access the module with the cab or computer (STP...) Externally (i.e. at the cab), the address is displayed as 900 ... 963 , internally as a CV however, it is stored as 0 ... 63. CV # 1 = 0, causes a HARD RESET - all CV's are reset to the default values including the address, which is set to 900. Normal reprogramming of the address to 900 DOES NOT cause a hard reset. It'll only change CV #1 to 0; all other CV's remain untouched.
# 2 # 3 # 4 # 5 # 6 # 7 # 8 # 9	Initial speed limits that are applied to the main sections after power-up: Main section 1 Main section 2 Main section 3 Main section 4 Main section 5 Main section 6 Main section 7 Main section 8	0 – 7, 100, 101, 102	0	In the default mode, all track sections remain unpowered at first (state "A") after the system is powered up and are set to "H" (stop) shortly thereafter. They remain in this mode until the first command is received from the command station or computer. In place of this initial state ("H" as default after start-up), each main section can be set to a different speed limit: = 0: see text above, „H“ (= Halt/Stop) after start-up = 1: „U“ (= Ultra low speed) = 2: „L“ (= Low speed) = 3: „F“ (= Free, unlimited speed) = 5, 6, 7: Intermediate steps „1/6“, „3/6“, „5/6“ = 100: Limits called by switch inputs: H - L - U - F = 101: Sequence A - H - L - F = 102: Sequence A - H - U - F
# 10 # 11	Function bits Main section 1 Main section 2	0 - 255	0	Each bit of the CV concerned corresponds to one of 8 function bits that can be actuated with the "location dependent function control" feature. One CV

CV	Name	Range	Default	Description
# 12 # 13 # 14 # 15 # 16 # 17	Main section 3 Main section 4 Main section 5 Main section 6 Main section 7 Main section 8			for each of the 8 main sections of the MX9. Identical for ALL operating modes
# 18	"Signal controlled speed influence" timing: Start of the "HLU" bits	0 - 255	SW <3.03=64 SW > 3.03=130	Problems, usually caused by wiring issues, which are affecting the operation of the MX9, can be compensated for with the help of these CV's. There is no need to change these settings under normal conditions!
# 19	Duration of HLU bits		136	Identical for ALL operating modes
# 20	Special configurations	0, 4, 8, 12	0	Bit 2 = 0: Signal outputs initialized when power-on. = 1: ... not initialized Bit 3 = 0: Normal operation of the track outputs = 1: High current operation; 2 outputs form parallel outputs each: 1A + 5A, 1B + 5B, 2A + 6A, 2B + 6B, etc.
# 21 # 22 # 23 # 24 # 25 # 26 # 27 # 28	Signal influenced block definition Main section 1 Main section 2 Main section 3 Main section 4 Main section 5 Main section 6 Main section 7 Main section 8	0	0	A value of "0" defines operating mode 2 or operating mode 3 for the respective main section
#29 #30			0	Do not change from default value 0!

“SYSTEM-AUTONOMOUS BLOCK CONTROL” –

Defining an “unidentified line”

The term “unidentified” indicates that the lines defined as such are not stored with a corresponding address. They can therefore not be called up, activated or deactivated. They are always active as long as they are not cancelled by overwriting it with a new definition.

Any number of unidentified lines, with as many blocks per line as needed, are permissible but each track section may only be part of one line. This means that, among other things, bidirectional lines are not possible.

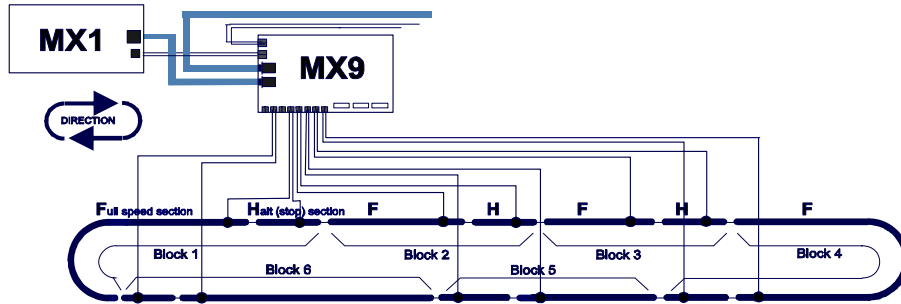

In contrast, “identified lines” are not restricted in any way and can be activated at will (see second half of this chapter).

The drawing above illustrates a typical layout for a “cyclical block operation” (closed loop). Typically a block is made up of one main section, whereas the two sub sections are the run and stop sections. A block can also be made with 3 sub sections, where 2 sub sections belong to one main section and a third sub section to another main section.

Each MX9 has to have its own exclusive address before the definition process is started (for address-procedures see chapter 4).

The **definition process** consists of **sample run** that involves driving a locomotive along the entire length of the line to be defined and by doing so the sequence and direction will be stored in the command station. A desired speed step is assigned, using the cab, to every section that is momentarily occupied by the loco: “F” for normal speed, “H” for a stop section and “L” or “U” for slow down sections. The loco can be stopped in each section to allow enough time for the operator to enter the desired speed step.

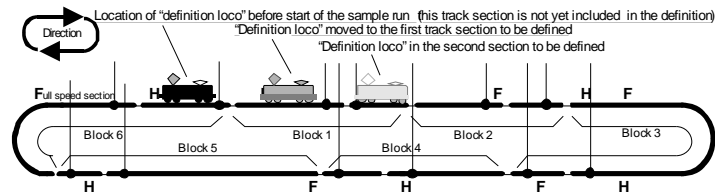

The assigned speed steps are used in later operations as follows:

- “F” = Full speed, as set by the cab, which may be different for each engine. This is a permanent setting.
- “H” = Halt (stop), train will stop if the following block is occupied, otherwise speed “F” is valid
- “L”, “U” = Low or Ultra low speed, train will slow down before entering the following stop section if the next block is occupied. This section is also set to “F” (together with the stop section that follows) if the next block is unoccupied.

STEP BY STEP EXAMPLE OF THE DEFINITION PROCESS:

Before starting the loco, all track sections to be defined have to be unoccupied. The loco used for this purpose is set on a track section before the first section to be defined. In case of a continuous loop that will be the last section of the line to be defined but this will not interfere with the definition process.

- The track and the loco’s wheels have to be clean to ensure reliable power pick up. Interrupted current flow due to bad contact may ruin the definition results.
- In case that only one cab (MX2, MX21, MX31 etc.) is available, the loco used for defining the line must be activated first. The loco will still obey the commands for speed, direction and the MAN key after the MX9 address is being entered in the next step. Headlights and other functions are not accessible but that is however not relevant for the definition run.
- The definition process can now be started by entering the fictitious address 999 and activate it with the A key. Fictitious because 999 is not a valid MX9 address. This is the start signal for the system that the definition process is about to begin, all track sections are now set to speed step H.
- Now drive the loco from its starting point (press the MAN key if the loco won’t move) into the first section and stop. All wheels of the loco have to be inside the section to be defined at the time any inputs are made through the cab.
- With the loco now sitting in the first section, the cab that showed the fictitious address 999 now displays the MX9 address connected to that section. The display of this address is for your information only. It is not really needed for the definition process.

The cab can now be used to define the speed limits for each section of the block. With the help of the function keys (#1 key for main section 1, #2 key for main section 2 etc.) the speed limits can be selected by cycling through the available limits. Only one key with its associated speed step indicator LED representing the main section the loco is now sitting is active and illuminated. Alternating with the MX9 address, the occupancy status of both sub sections is also shown. Instead of the letter “b” for busy the actual speed step applied (F-L-U-H) is shown (additionally to the colored indication of the LED).

As a reminder: F (Full speed) = green; L (Low speed) = yellow; U (Ultra low speed) = orange; H (Halt, stop) = red

For example: With the loco sitting in sub section A of the first main section of MX901, the display would alternate between 901 and H_. H, because the speed of this section is set to H (Halt), the LED above the F1 key is illuminated in red, also indicating speed step H. By repeatedly pressing the appropriate function key the speed step for this sub section is now being defined. As you scroll through all available speed steps (F-L-U-H), they will be indicated on the LCD and LED except step A, which is not available here. The speed step that is indicated when the loco is driven out of this section is automatically stored.

The first section is now defined.

- The loco is now driven from section to section. In each section, stop the loco (which is done automatically if the MAN key is not active) and enter the desired speed step for this section as explained above.
- In sections where the speed is defined to F, L or U, the selected speed step will be applied after 2 seconds and the loco will start up automatically at the speed corresponding to this step (defined in loco decoder CV #51 - #55), provided the speed regulator is not set to 0. In a sub section defined to speed step H, the loco can only be driven out by activating the MAN key.
- The entire definition is done for each sub section, that is, the speed step definition (F, L, U, and H) is done independently and may very well be different for each sub section that belongs to the same main section. During operation though, both sub sections that are part of a main section will always be set to the same speed step. For example, a train is supposed to stop at the end of a block, because the next block is occupied. When the loco enters the second sub section of a main

section, not only is this second sub section set to H but the first sub section as well. This is needed in order to get a train stopped in front of a red signal where the engine is at the back, as in a push-pull operation, or with a helper engine at the end of a train.

- The definition run is continued in this fashion until the last track section belonging to this line is reached.

There are different kinds of lines:

- line with an unsecured exit, where the last sub section is defined as an F, L, or U but not H. This kind of line is characterized by the fact that a train in an operating layout is always leaving this line into the next, possibly unsecured part of the layout.

- line with a secured exit, always ends with its last sub section defined to H. In operation, all trains come to a stop at the end of this line and can only be driven out of this section by activating the MAN key.

- continuous line (probably the most frequently used form). A loco can be run through the line a second time, if corrections are needed to be made, while still in the definition process. In this way, all sections can be tested since the previously programmed speed steps are now applied to them. The loco will always stop in an H section as if the following block was occupied and can only be driven out by using the MAN key.

A definition run is cancelled with an automatic broadcast stop (SSP) if:

- the memory of the MX1 is full or
- the loco is used to define an already defined section, which is only allowed once during the original definition run to make speed step corrections, as mentioned above.

NOTE:

No special procedure is given to **erase** unidentified lines. However, the complete line will be erased if any of its sub sections become part of a newly defined line. Regardless whether the new line is an unidentified, identified or a computer controlled line.

DEFINITION AND APPLICATION OF AN IDENTIFIED LINE:

An identified line is defined with the help of a cab similar to the unidentified line. It requires the definition of a turnout ladder, which also includes a definition run as above and is stored in the command station. Routes that include specific turnout positions can be stored and called up on demand which makes a block controlled route through a station possible. The turnout ladder number becomes the identifier with which the route can be called up!

See cab instruction manual!

“AUTOMATIC ROUTE SEQUENCES” - A R S

PROJECT UNDER DEVELOPMENT!

11. OPERATING MODE 3

MX9 under COMPUTER control

In operating mode 3, all MX9 functions are controlled by the computer (usually with STP software) – this is also the original application for which the MX9 was developed. It doesn't matter to the MX9 itself whether it is operated in mode 2 (see above) or 3, in both cases control is taken over by a processor in the form of a command station or a computer.

The configuration variables are therefore identical to the ones in the previous chapter and the same CV table is printed below, although that could change through software extensions in the future.

References and tips to MX9 track section arrangements for computer controlled layouts are given after the CV table!

CV	Name	Range	Default	Description
# 1	Module Address (stored without the leading "9") Identical for ALL operating modes	0 – 63 = 900 – 963 Programming a new address is only possible if module address is 900! Programming to address 900 = deleting current address	0 = 900	The address that is used to access the module with the cab or computer (STP...) Externally (i.e. at the cab), the address is displayed as 900 ... 963 , internally as a CV however, it is stored as 0 ... 63. CV # 1 = 0: causes a HARD RESET - all CV's are reset to the default values including the address, which is set to 900. Normal reprogramming of the address to 900 DOES NOT cause a hard reset. It'll only change CV #1 to 0; all other CV's remain untouched.
# 2 # 3 # 4 # 5 # 6 # 7 # 8 # 9	Initial speed limits that are applied to the main sections after power-up: Main section 1 Main section 2 Main section 3 Main section 4 Main section 5 Main section 6 Main section 7 Main section 8	0 – 7, 100, 101, 102	0	In the default mode, all track sections remain unpowered at first (state "A"), after the system is powered up and are set to "H" (stop) shortly thereafter. They remain in this mode until the first command is received from the command station or computer. In place of this initial state ("H" as default after start-up), each main section can be set to a different speed limit: = 0: see text above, „H“ (= Halt/Stop) after start-up = 1: „U“ (= Ultra low speed) = 2: „L“ (= Low speed) = 3: „F“ (= Free, unlimited speed) = 5, 6, 7: Intermediate steps „1/6“, „3/6“, „5/6“ = 100: Limits called by switch inputs: H - L - U - F = 101: Sequence A - H - L - F = 102: Sequence A - H - U - F
# 10 # 11	Function bits Main section 1 Main section 2	0 - 255	0	Each bit of the CV concerned corresponds to one of 8 function bits that can be actuated with the "location dependent function control" feature. One CV

CV	Name	Range	Default	Description
# 12 # 13 # 14 # 15 # 16 # 17	Main section 3 Main section 4 Main section 5 Main section 6 Main section 7 Main section 8			for each of the 8 main sections of the MX9. Identical for ALL operating modes
# 18	"Signal controlled speed influence" timing: Start of the "HLU" bits	0 - 255	SW <3.03=64 SW > 3.03=130	Problems, usually caused by wiring issues, which are affecting the operation of the MX9, can be compensated for with the help of these CV's. There is no need to change these settings under normal conditions!
# 19	Duration of "HLU" bit		136	Identical for ALL operating modes
# 20	Special configurations	0, 4, 8, 12	0	Bit 2 = 0: Signal outputs initialized when power-on. = 1: ... not initialized Bit 3 = 0: Normal operation of the track outputs = 1: High current operation; 2 outputs form parallel outputs each: 1A + 5A, 1B + 5B, 2A + 6A, 2B + 6B, etc.
# 21 # 22 # 23 # 24 # 25 # 26 # 27 # 28	Signal influenced block definition Main section 1 Main section 2 Main section 3 Main section 4 Main section 5 Main section 6 Main section 7 Main section 8	0	0	A value of "0" defines operating mode 2 or operating mode 3 for the respective main section

Connecting track sections to the MX9 is the same regardless of the operating mode chosen. Only one rail, the one connected to output "P" of the command station, needs to be divided into sections. The other is connected as one continuous rail to the output marked "Schiene N" at the back side of the MX1. Each double socket belongs to one main section which provides terminals for two sub sections.

ATTENTION: The system depends heavily on a good ground circuit. A poor wiring job or not enough feeder wires connected to the "N" rail may cause different kind of problems such as the unexplained dropping of train numbers, a stopped train creeping out of a stop section, etc!

A MAIN SECTION is made up of two side by side sub sections, which share the signal controlled speed influence (i.e. identical speed limits, identical function control and identical position codes on

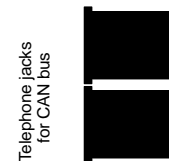

1 2 3 4 5 6 7 8
A B A B A B A B A B A B A B A B

Sockets for 16 track sections
One double socket equals one main section

each sub section) and train number recognition.

A SUB SECTION is half a main section. While each sub section recognizes track occupation independently, train number recognition and signal controlled speed influence is always carried out for the main section.

The track sections connected to the 16 outputs of the MX9 (or connections of several MX9's) are not fixed to specific functions. Later, the functions will be defined by either a computer with STP software or the cab. Just remember that two sub sections (A + B) always belong to the same main section (with the same speed limit commands etc.).

The following are a few examples of how to create and connect track sections to one or several MX9 modules.

Please note the terminology used to indicate section functions by Zimo and STP:

F = Full speed, L = Low speed, U = Ultra low speed, H = Halt (Stop), A = Auto power off.

EXAMPLE – Simple block control consisting of drive and stop sections

In such an application, one main section equals one block. The two sub sections are the drive (F) and stop (H) section.

This drawing illustrates one possible track section connection to an MX9, where all sections are connected in series.

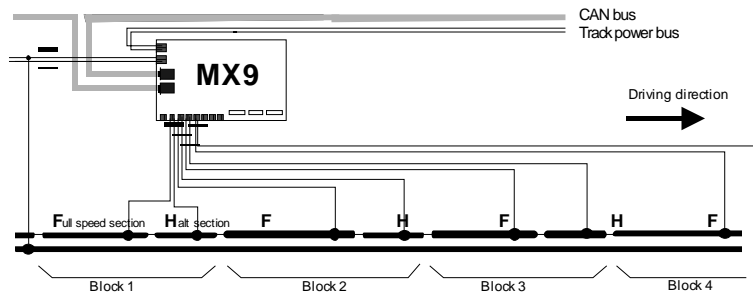

An alternative hook up is shown in the drawing below. Here, the blocks are connected to two MX9 modules. It is important to note that here too; the two track sections that make up the block are assigned to the same main section. What looks like a very inefficient use of track section modules, may in reality be very practical on a modular layout, for example. This would simplify the wiring between the layout modules, plus the unused main sections may be used for other blocks on the same layout module.

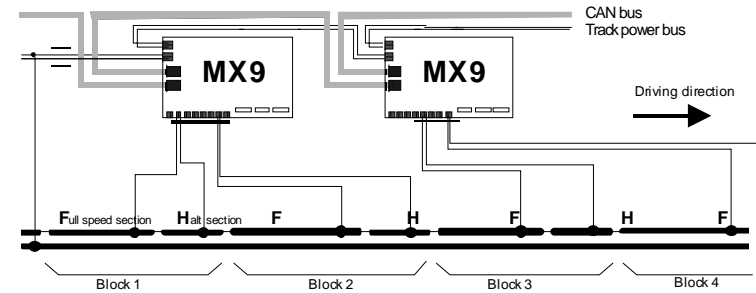

Tips on track section lengths:

- All stop sections on a line between stations whose blocks are made up of F and H sections only, should be of equal length.
- The length of a stop section depends on whether the previous section is programmed as a brake section and on how the loco decoder is set up (i.e. CV #4 for general momentum, CV #50 for "signal controlled momentum").
A typical stop section length for HO without the use of a brake section is between 5 - 8 feet (1.5 - 2.5m). By implementing a brake section, 1.5 - 2 feet (.4 - .6m) should be sufficient in most cases.
- The length of an F section may be different in each block but should be at least as long as the longest train on the layout.
- It is largely a matter of personal taste on how fast a train should come to a stop. This can be selected by changing the CV's of the loco decoder. The longer it takes for a train to come to a stop, the longer the brake and/or stop sections have to be. It is therefore highly recommended to do some trial runs first and then plan the section lengths for the whole layout exactly.

EXAMPLE – Blocks with more than two sections

It can be practical for several reasons to divide a block in to 3, 4 or more sections. Some of those reasons are: increased precision of stop points by reducing speed in an L and/or U section before

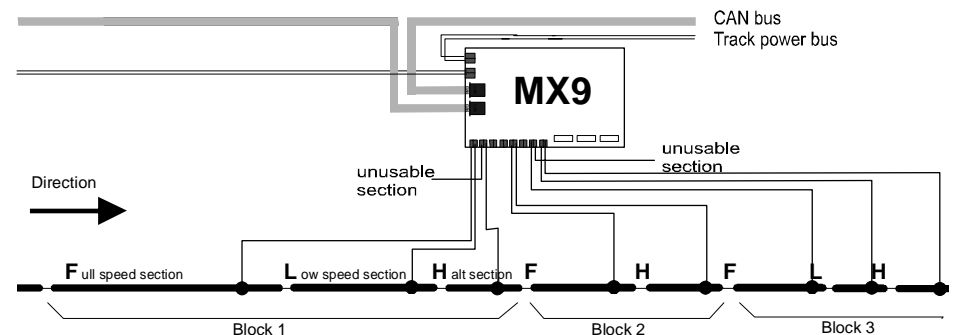

stopping or for a more detailed occupancy indication. Some connections of the MX9 may not be used in case of an uneven quantity of sections. It is not allowed to use sub sections belonging to the same main section in two different blocks.

The drawing below once again shows one of many possible ways to connect a MX9 to the layout. This time only one MX9 is shown that is connected to blocks with an uneven number of track sections. Blocks with just two track sections may be mixed with blocks containing several sections. A block with three track sections may be connected to two main sections (double sockets). It doesn't matter whether an F section is paired with an L section, or an L with an H section. As already mentioned, connecting three sections of one block to two double sockets require that one connection remains unused.

Length of low speed sections:

Low speed sections are usually used to slow down a train ahead of a stop section. A low speed section is set to low speed only, if the train is expected to stop in the following section.

All slow down sections of a layout have to be of identical in length and are typically about twice as long as the stop section, about 3 - 5 feet (1 - 1.5m) for HO.

**EXAMPLE –
Blocks in a continuous loop**

The number of trains that can operate in a closed loop with block control is always one less than the number of blocks available. 7 trains can safely operate on such a layout with only one MX9, 15 with two MX9 etc. That is, with 8 blocks made up of one F and one H section. Fewer trains, if blocks contain more than two sections.

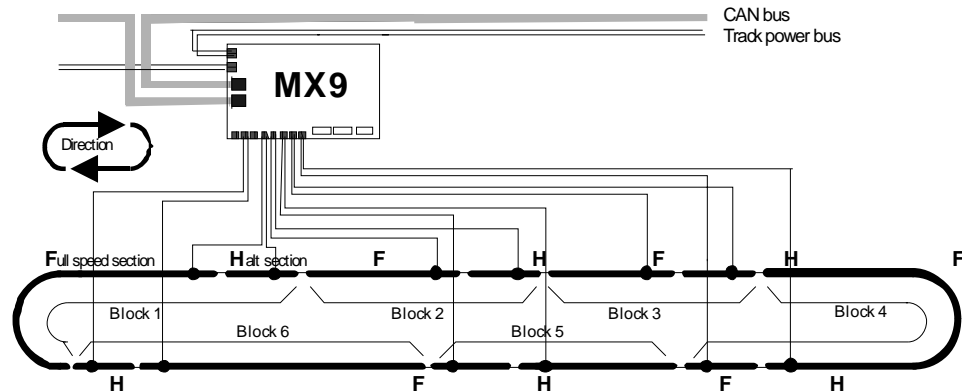

**EXAMPLE –
Bidirectional block control**

In a bidirectional line like this, the travel direction determines the block sequence. For this reason only one connection of the double socket can generally be used.

Track section module MX9

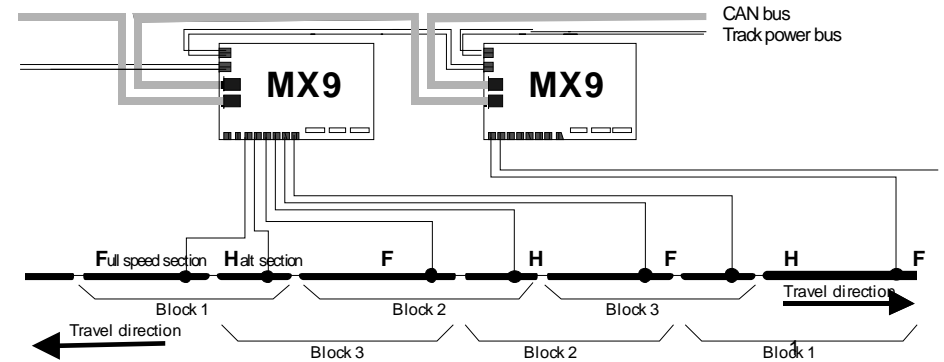

**EXAMPLE –
Unidirectional stations (i.e. staging yards)**

In unidirectional stations, each platform track is usually split into two sections, whereby the second section is the stop section. Both of those sections are connected to one double socket of a main section at the MX9 module. Of course, all tracks can be used in both directions when driving in manual mode (e.g. shunting work).

The sections before the stop section are commonly used for slow station entries and would have a low speed limit applied to, such as L or U.

A main section is used for each track section containing turnouts at each end of the station. The other sub section of those main sections must not be used. The line before and after the station is usually part of a block as described in the previous examples.

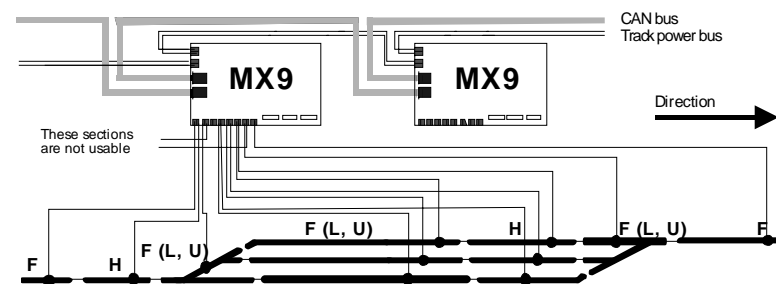

**EXAMPLE –
Bidirectional station**

In order to have stop sections in the right places and of suitable length, a platform track in a bidirectional station needs to be separated into at least 3 sections.

If two or more lines enter or exit a station, as shown at the right end in this example, special consideration is to be paid to the section configuration in the turnout area. Because a section cannot be used in two different routes at the same time, track sections that can be used for parallel entry or exit

routes should not overlap each other, if such parallel movements are desired. In some cases a section may consist of just one turnout. This is especially true for double crossovers.

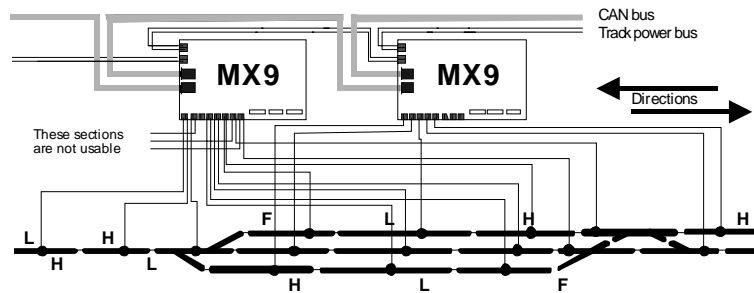

Fundamental considerations - when planning track sections in complex situations:

The previous examples dealt with some basic track configurations. They can't be used as an illustration for every conceivable station or line. The designer has to keep certain principles in mind when planning his or her layout. These are as follows:

- A stop section has to be provided for every stop point intended at the end of a route or block. See example #1 for stop section length.

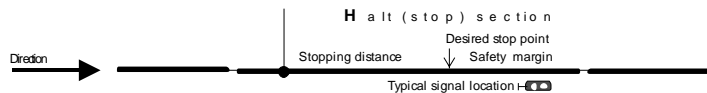

- Low speed sections are placed before a stop section in order to slow down a train before it enters the usually short stop section. Low speed sections can later be assigned to speed step L (= low speed) or U (= ultra low speed) during the route definition.

Reducing a train's speed improves the accuracy of an intended stop point. The accuracy increases the slower the train is before it enters a stop section. It follows that a stop section may be shorter with a low speed section set to speed step U as compared to speed step L.

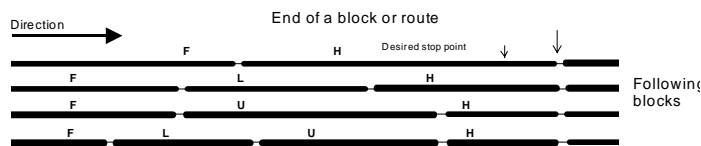

- F, H, L and U sections can be assigned to track sections in any sequence that is practical, e.g. to place the low speed and stop sections in the proper order and length when used in both directions. Obviously, the L and U sections have to be long enough so that the train has enough time to actually decelerate to its intended lower speed before it enters the H section.
- Track sections when used in route or block control must not belong to more than one active route at a time, with the exception of two consecutive routes overlapping each other. Therefore no track section may be part of two routes that can be activated at the same time.

- The two subsections of a MX9 main section can be connected to track sections that will need the same speed limit applied to in all operational circumstances (F, L, U, and H).

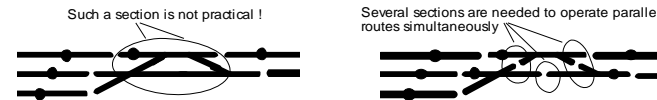

- This will be the case with track sections in a block or a platform track. If for instance a bidirectional platform track is made up of three sections, any two sections may be selected as one main section and the remaining section connected to another main section. The other half of that main section has to remain unused. It makes sense to select the two stop sections as a main section when train number recognition is employed.

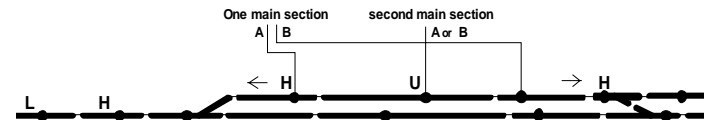

- Carefully consider which sections in a turnout area should be joined to one main section:

These track sections must not be part of the same main section since each of them could be part of a different route at the same time. Unless, of course, parallel entry and/or exit operations are not intended.

These two sections, on the other hand, may be part of the same main section. All conceivable routes that are practical include both sections. If a route is selected that includes only one of them no other route can be set at the same time.

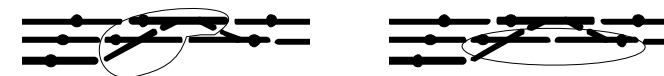

FOR FURTHER EXPLANATIONS TO TRACK SECTION ZONING –

Consult the STP manual !

12. Replacing the EPROM

After powering down the system or disconnecting the MX9 remove the 3 Phillips screws holding the Plexiglas cover (some versions only use the two front screws to hold the cover in place). Note the position, with its index markings on the EPROM and the socket. The EPROM is removed from its location (upper right corner) by using a screw driver placed underneath it and carefully lifting it up. Do not bend the small pins.

Install the new EPROM with the index mark in the same position. Make sure that all pins are actually inserted and none of them are bent!

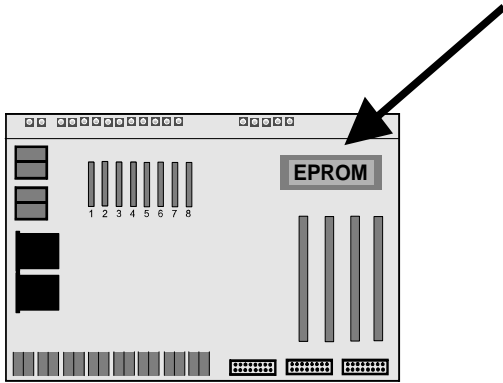

13. Increasing the threshold for occupancy detection

In some cases it may be necessary to increase the threshold of occupancy detection for selected track sections by either raising the current flow above the standard value or decreasing the resistor across axles (see page 3). A false occupancy indication due to dampness in a garden railroad may be prevented with this measure. This may also be useful to prevent a wrong occupancy indication in a return loop section controlled by an MX7 module.

Of course, raising the threshold of occupancy detection causes some vehicles with resistance axles (without lighting or motor) not to be recognized anymore.

The modification is done for individual track sections at the MX9 board. Remove the board by unscrewing cover and the threaded cover supports. An additional resistor is soldered to the appropriate track section circuit.

The following drawing illustrates the position for installing the resistors of track sections 1A, 1B, 8A and 8B, as an example. The top side of the board is shown but the resistors are soldered on the opposite side to the rectifier pins of the 8 main sections.

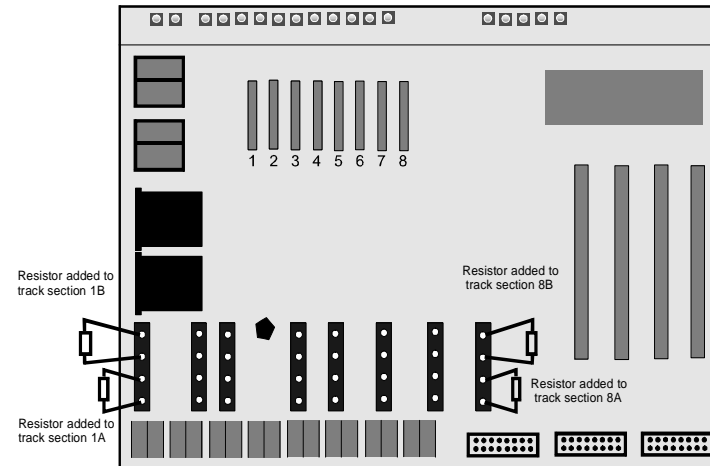

Trial and error determines the value of the resistors. For example, a 330 Ohm resistor doubles the current flow required for track occupancy detection, which in turn cuts the value needed for the axle resistor in half (e.g. at 20V from a 22k to a 11k resistor). Smaller resistors installed to the board, such as 100 Ohm, 47 Ohm etc., will reduce the sensitivity even further.

14. MX9 modifications for MX9ASE applications

Also see chapter 4 if the MX9 was not delivered with this modification;

ATTENTION:

the **MX9 module** must be **modified** before MX9ASE plug-in boards can be installed and switches used as input signals. MX9ALA boards on the other hand can be installed at any time

This modification is performed by ZIMO on request (additional internal conductors from the processor to the plug-in sockets, which are not present on the printed circuit board), even after the modules have been delivered.

Remove the acryl cover and bottom plate. The modification requires the connection of the following points with thin wires (also see photo below):

- from IC 74HC138 (the one on the left), Pin 10 – to the first and third 20-pin connector, pin 9 on both (counted from the front, connector side)

- from IC 74HC138 (also the one on the left), Pin 11 – to the second and fourth 20-pin connector, also to pin 9 on each (counted from the front, connector side)

The two pictures show one way to make these connections. Two unused holes (they were originally planned for something else), shown in the left picture, are used to bring the wires from one side of the board to the other. The wires could also be brought to the other side by wrapping them over the outside edge of the board if preferred.

Top view

Bottom view

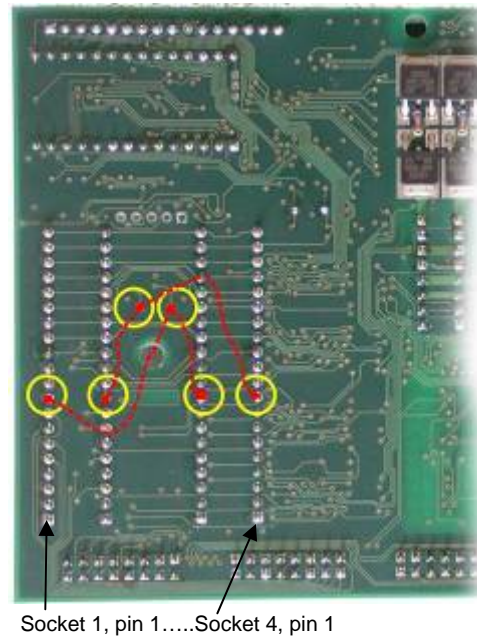
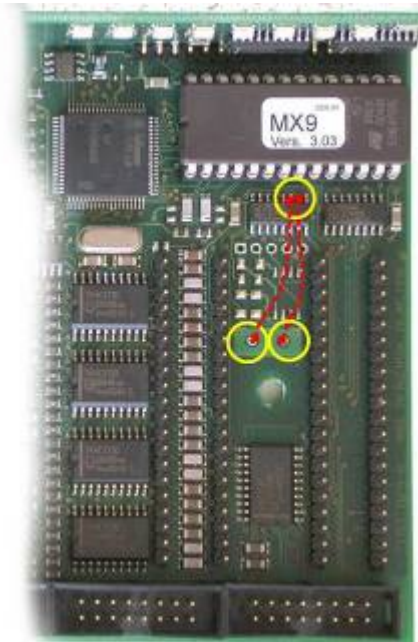

Socket 1, pin 1.....Socket 4, pin 1

15. Glossary

CAN bus:

Is an international standard for the secure data transfer between electronic modules and control units. It is used in the automotive industry, among others. ZIMO is using this protocol via the cables (CAN bus cable) connecting the command station with the cabs, accessory modules, track section modules, turn table modules, computer and more.

The CAN bus cable is also known as the cab cable.

Also see: ZIMO system prospectus or info at www.zimo.at !

Signal controlled speed influence (aka: „location dependent control“, „HLU“ - method):

For prototypical train operation more is needed than just the ability of controlling more than one locomotive per track as is the case with DCC. Secure train operation, as in centralized traffic control is also part of it and involves signals, block control, route control etc.

The conventional method of cutting power to stop trains in front of a red signal is not a satisfactory one using DCC. For one, all functions become inaccessible (lights, smoke etc.) and the prototypical slow stopping and acceleration of trains is not possible.

ZIMO made it possible by integrating a special process of a signal dependent train control in the affected components (especially loco decoders) of the DCC system. Additional control information is sent to the track section that is supposed to stop a train automatically. When a train enters this stop section (H section), it will come to a prototypical stop, that is with the lights and all other auxiliary equipment still operating,

Also see: ZIMO system prospectus or info at www.zimo.at !

Turnout ladder:

Under turnout ladder we mean a number of turnouts and their positions. Which turnouts that become part of such a ladder and what position each has to be in, needs to be defined first and can later be called up on demand.

Note: In literature of other model railroad manufacturers, turnout ladders are often referred to as routes. ZIMO uses the term route for higher levels of operation that combines turnout ladders and track section control for automation and collision avoidance (which is most often not available with other systems and therefore requires no distinction either).

Route:

A route as used here is an extended turnout ladder. It is a combination of turnouts and their intended positions, track sections (connected to track section modules MX9) and may also include push buttons panels.

Line, Block, unidirectional, bidirectional:

The term Line is used for a length of track, usually connecting two stations, consisting of a series of blocks. A block is a series of at least two track sections of which the last is usually a stop section.

Unidentified lines do not have an address assigned by which they could be activated. They are always active as long as they exist, that is, are not overwritten by a new definition process. They are especially simple to define and use but are limited in their application compared to identified lines, which are defined as part of a turnout ladder.

Unidirectional or bidirectional means that a track may be used in one direction only or both. Routes and lines are by definition unidirectional. The actual track, on the other hand, can be bidirectional. Each direction is then defined as a separate route or line.

